

optional
stainless steel

single-position
multi-position
full disengagement

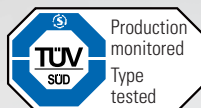

MODEL SLE

BACKLASH FREE TORQUE LIMITER

with clamping hubs and elastomer insert

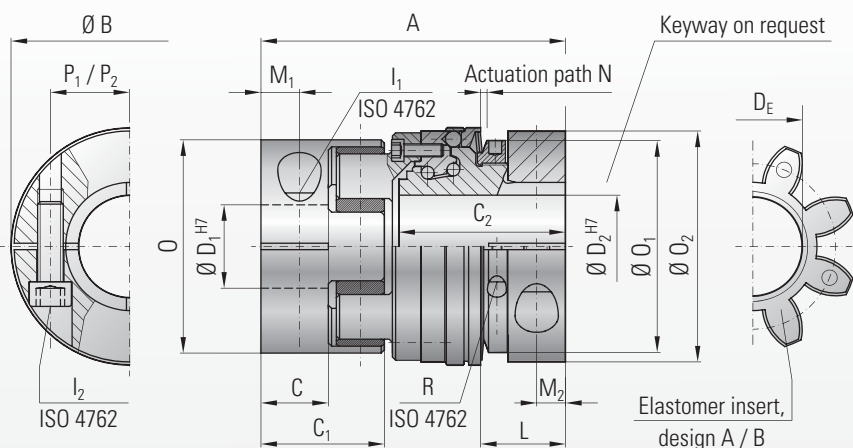

Design:

Clamping hub with one ISO 4762 screw per hub. Components of compact and rigid design with backlash free interface. Misalignment compensation via elastomer insert

Temperature range: -30 to +100°C

Service life: These couplings are maintenance free and stable over their entire service life if technical limits are not exceeded

Fit tolerance: Overall clearance between shaft and hub 0.01-0.05 mm

Function system:

W = single position engagement (standard)

D = multi position engagement every 60°

(30, 45, 90° optional)

F = full disengagement on request

Model SLE	Series							
	30		60		150		300	
Type (elastomer insert)	A	B	A	B	A	B	A	B
Rated torque	T _{KN} 60 75		160 200		325 405		530 660	
Max. torque	T _{KN max} 120 150		320 400		650 810		1060 1350	
Adjustment range* from - to (Nm)	T _{KN} 10-35 30-80 40-135		30-80 60-120 100-200		40-100 100-200 150-300		200-350 300-450 400-550 550-700	
Overall length (mm)	A 85		93		122		135	
Actuation ring diameter (mm)	B 63		74		92		118	
Hub length (pure coupling end) (mm)	C/C ₁ 20 / 36		21 / 39		31 / 52		34 / 57	
Hub length (torque limiter end) (mm)	C ₂ 45		53		63		72	
Bore diameter from Ø to Ø H7 (mm)	D ₁ /D ₂ 12-32 / 12-30		16-36 / 16-35		19-45 / 19-48		22-60 / 22-60	
Inner diameter (elastomer insert) (mm)	D _E 26,2		29,2		36,2		46,2	
ISO 4762 screw, coupling side / torque limiter side	M6		M8		M10		M12	
Tightening torque (Nm)	I ₁ /I ₂ 15		40		75		130	
Distance to actuation ring edge (mm)	L 22		26		32		35	
Distance (mm)	M ₁ /M ₂ 10 / 7,5		12 / 9		15 / 11		17,5 / 12	
Actuation path (mm)	N 1,3		1,5		1,8		2	
Clamping hub Ø, elastomer coupling (mm)	O 56		66,5		82		102	
Adjustment nut Ø (mm)	O ₁ 55		66		82		100	
Clamping hub Ø, safety coupling (mm)	O ₂ 59		72		90		112	
Distance to clamping screw, coupling side / torque limiter side (mm)	P ₁ /P ₂ 21 / 21,5		24 / 25		29 / 33		38 / 41	
Adjustment nut's clamp screw ISO 4762	R M3		M3		M3		M4	
Tightening torque (Nm)	R 2		2		2		4,5	
Approx. weight (kg)	0,4		0,8		1,5		2,9	
Approx. moment of inertia at D max. (10 ⁻³ Kgm ²)	J _{ges} 0,3		1		1,8		5	
Static torsional rigidity (Nm/rad)	3290 9750		4970 10600		12400 18000		15100 27000	
Dynamic torsional rigidity (Nm/rad)	7940 11900		13400 29300		23700 40400		55400 81200	
Lateral ± max. (mm)	0,12 0,1		0,15 0,12		0,18 0,14		0,2 0,18	

Static torsional rigidity at 50% T_{KN} Dynamic torsional rigidity at T_{KN} * max. transmittable torque depends on the bore diameter; see table on page 4. (1Nm = 8.85 in lbs)

max. offsets for elastomer insert



Angular misalignment
± 1°

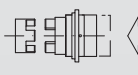

Axial misalignment
± 2 mm

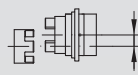

Lateral misalignment
see table above

Ordering specifications

SLE / 060 / A / W / 30 / 20 / 80 / 60-120 / XX

Model	SLE
Series	060
Elastomer insert design	A
Function system	W
Bore Ø D1H7	30
Bore Ø D2H7	20
Disengagement torque (Nm)	80
Adjustment range (Nm)	60-120
Special feature, e.g. stainless steel	XX