

LP1

WITH KEYWAY MOUNTING

350 - 20,000 Nm



ABOUT

FEATURES

- ▶ very high torsional stiffness
- ▶ single flex design
- ▶ wear and maintenance free

MATERIAL

- ▶ **Disc pack:** highly elastic spring steel
- ▶ **Hubs:** high strength steel

DESIGN

Two precision machined coupling hubs mounted to the disc pack by means of high strength screws and bushings for alignment and frictional clamping of the assembly. Axial retention with DIN 916 set screws.

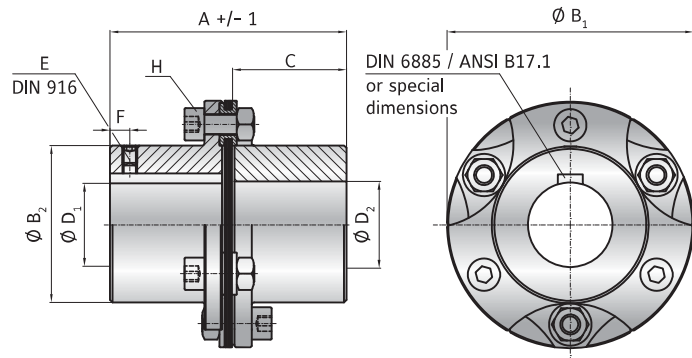

MODEL LP1

SIZE		300	700	2000	4000	7000	10000
Rated torque (Nm)	T_{KN}	350	700	2000	4500	7600	10000
Maximum torque (Nm)	T_{Kmax}	700	1400	4000	9000	15200	20000
Overall length (mm)	A	95	116	158	193	216	268
Outside diameter (mm)	B_1	99	128	150	198	238	298
Hub diameter (mm)	B_2	63	78	86	120	140	194
Hub fit length (mm)	C	45	55	75	90	100	125
Bore diameter available from \emptyset to \emptyset H7 (mm)	$D_{1/2}$	18 - 48	25 - 58	28 - 64	38 - 90	50 - 102	70 - 140
Set screw (DIN 916)	E	see table (depends on bore diameter)*					
Distance to screw (mm)	F	15	15	20	20	25	30
Assembly screw (ISO 4762) Nut (DIN 934)	H	M8	M10	M16	M20	M24	M24
Tightening torque (Nm)		38	75	320	650	1000	1100
Moment of inertia ($10^{-3}kgm^2$)	$J_{ges.}$	1.8	5.6	13.9	52.2	127	412
Material		steel	steel	steel	steel	steel	steel
Approximate weight (kg)		2	3.8	6.7	13.3	20.9	41.4
Torsional stiffness ($10^3Nm/rad$)	C_T	470	1200	1500	3600	6000	13300
Axial \pm (mm)		0.5	0.75	1	1.25	1.25	1.5
Angular \pm (degree)		0.7°	0.7°	0.7°	0.7°	0.7°	0.7°
Maximum speed (1/min.)		10000	8000	6000	5000	4500	4000
Bore range \emptyset (mm)		\emptyset 18 - 30	\emptyset 30.1 - 44	\emptyset 44.1 - 65	\emptyset 65.1 - 85	\emptyset 85.1 - 110	\emptyset 110.1 - 140
Set screw size*		M5	M8	M10	M12	M16	M20

ORDERING EXAMPLE	LP1	700	42	38.1	XX
Model	●				Special designation only (e.g. special bore tolerance).
Size		●			
Bore D1 H7			●		
Bore D2 H7				●	
For custom features place an XX at the end of the part number and describe the special requirements (e.g. LP1 / 700 / 42 / 38.1 / XX; XX = stainless steel)					