

Timing Belt Conveyors ZRF-P 2040

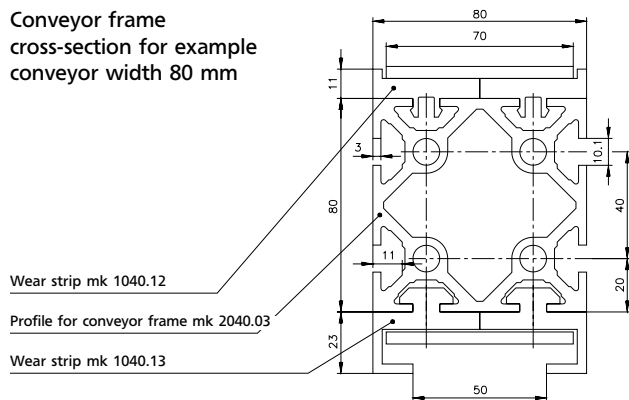

Conveyor frame
cross-section for example
conveyor width 80 mm





The ZRF-P 2040 timing belt conveyor system is designed especially for product cycle operation applications where a cleated, or fixtured timing belt is required, or for wider timing belt applications. Timing belts are available with a variety of backing materials, or with welded fixtures. Many cleats are available. Plain cleats,

as shown at left, are used for product separation. Others are available with threaded inserts for customer installed fixtures. This conveyor is ideal for special conveying requiring positioning or loading of products. Depending on the product and the application, custom fixtures and other belt widths are available.

ZRF-P 2040 AC

Timing belt conveyor with head drive standard

B20.40.301

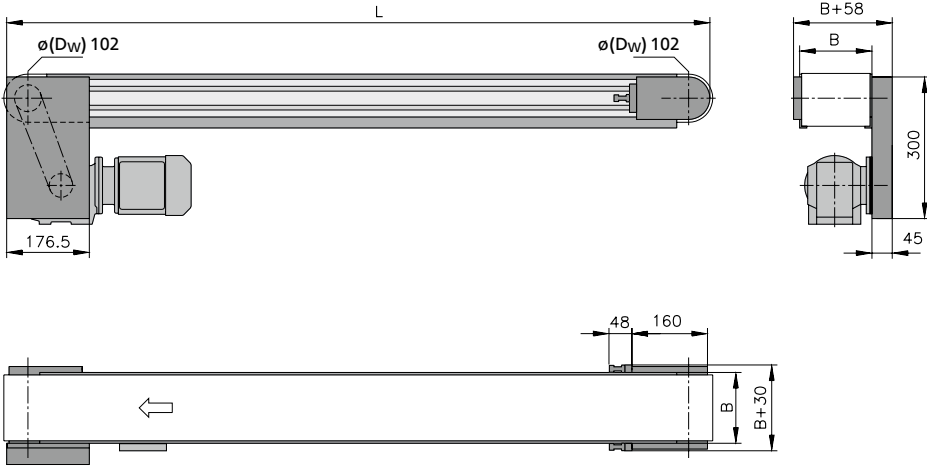

Use of timing belts with fixtures possible with this drive version. When using cams, the max. possible height must be requested.

	Dimensions – technical information	Notes
Conveyor length L	individually 650-6000 mm	any increment possible
Conveyor width B	40/80/120/160 mm	others on request
Timing belt width	32/70/110/150 mm	
Timing belt type		timing belts see page 158
Drive location	discharge side left/right below	
Drive and speed	to 60 m/min (200 ft/min) higher on request	see chart on page 12
Stands and side rails		see from page 262
Load capacity	total load to 125 kg section load to 50 kg/m for B = 40 mm total load to 250 kg section load to 100 kg/m from B = 80 mm	higher on request

ZRF-P 2040 AS

Timing belt conveyor with outside head drive

B20.40.302

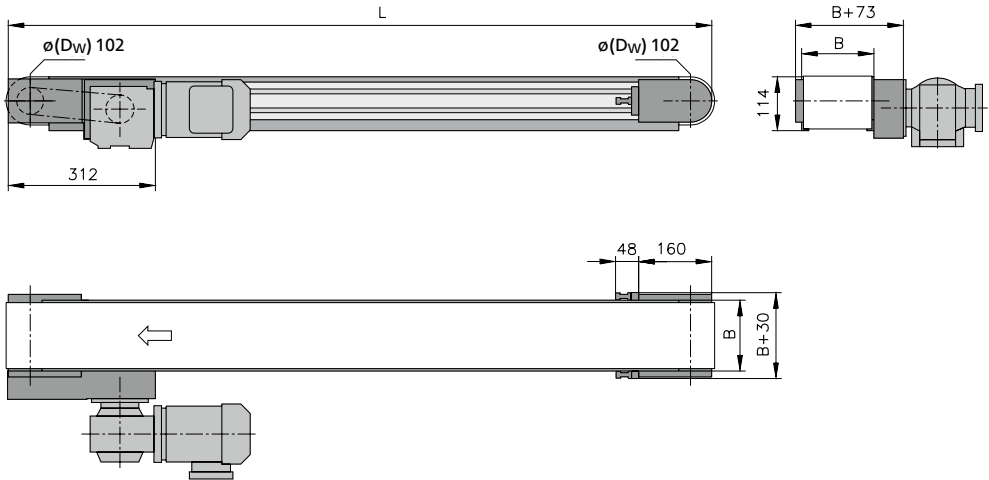

The overall height of the drive assembly is held to an absolute minimum. The timing belt pulley ensures outstanding transmission of the motor power. Use of timing belts with fixtures is possible without restriction with this drive version.

	Dimensions – technical information	Notes
Conveyor length L	individually 650-6000 mm	any increment possible
Conveyor width B	40/80/120/160 mm	others on request
Timing belt width	32/70/110/150 mm	
Timing belt type		timing belts see page 158
Drive location	discharge side left/right	
Drive and speed	to 60 m/min (200 ft/min) higher on request	see chart on page 12
Stands and side rails		see from page 262
Load capacity	total load to 125 kg section load to 50 kg/m for B = 40 mm total load to 250 kg section load to 100 kg/m from B = 80 mm	higher on request